

PRODUCT INFORMATION AND SPECIFICATION SHEET

DAMIER KEYPADS – 82 MM



DAMIER KEYPADS – 82 MM || PRODUCT INFORMATION

DESCRIPTION

Damier collection push buttons keypads for use with lighting control / home automation systems. Compatible systems include Crestron, Control4, Lutron HomeWorks, Savant and Vantage.

Made in France.

PERSONALIZED PLATE DETAILS

FINISHES

Cover plates are made-to-order in any of the finishes included in the [Meljac Finish Catalog](#). Meljac offers over 30 finishes in materials including chrome, copper, gunmetal, nickel, brass and bronze.

Powdercoating is available in any specification from the [RAL Color Chart](#).

Custom-matched finish options are also available, dependent upon project size and finish details.

MECHANISM

Low-voltage momentary dry contact buttons for use in class-2 wiring circuits only.

- BP - Momentary Push Button ("normally-open"). One contact closure.

BUTTON OPTIONS

Damier collection buttons are available in multiple shapes and may be raised or flush with keypad plate surface

- Square
- Round
- Triangle
- Flush with plate surface
- Raised above plate surface

SCREW TYPE

- Hidden

EDGE TYPE

- Straight (default)
- Beveled

LED FEEDBACK

- 3 mm or 8 mm LED Indicators
- Backlit Engravings
- 12V or 24V remote power required.

ENGRAVINGS

- Available above, below, or on top of button
- Default: 3 mm / Arial Font / Mechanical Style
- 9 characters per line + 2 lines per mechanism

See [MNA Engraving Options](#) for more details.

BACK BOX

Recommended: MELUS8282R - Metal ring for 3rd party 4" x 4" electrical boxes.

Alternate Option: MEL8080 plastic cut-in box.

See our [Plate Size & Back Box Guide](#) for more information.

CERTIFICATION

Conforms to UL 916 and CSA-C22.2 No. 205-12 IP20



CARE / CLEANING INSTRUCTIONS

To protect the integrity of the finish, no chemicals or cleaning solutions should ever be used. Dry dust rags or microfiber cloths only.

DAMIER KEYPADS – 82 MM || DIMENSIONAL DRAWINGS

DIMENSIONAL DRAWINGS

Measurements: mm (inches)

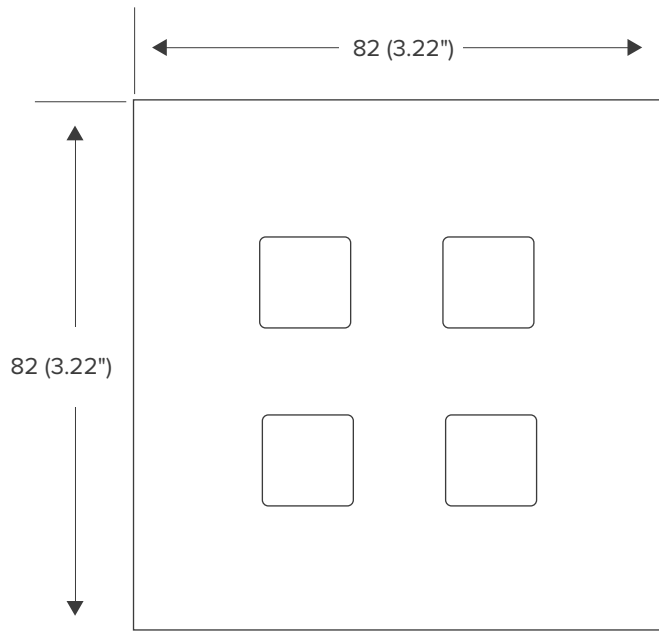

Flush Button Option

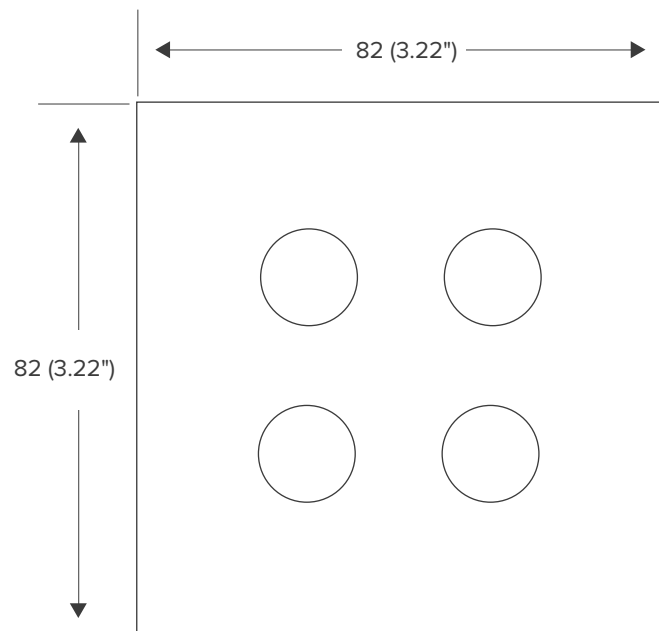
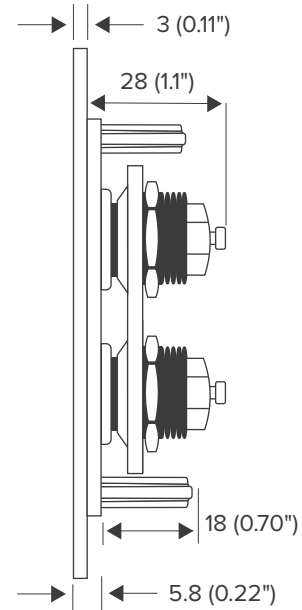

Raised Button Option

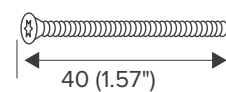
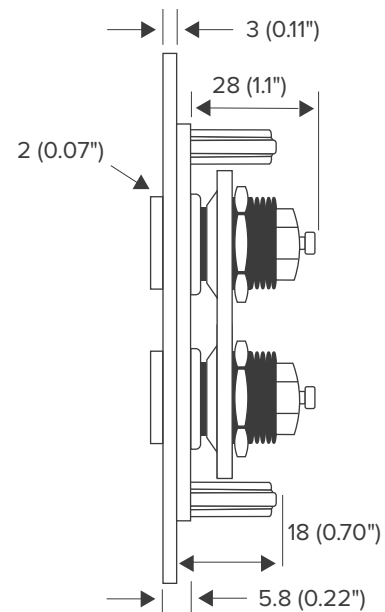

Supplied 6-32
Flat Torx Head
Machine Screw

DAMIER KEYPADS – 82 MM || MOUNTING DRAWINGS

BACK BOX

MELUS8282R - Metal ring for 3rd party 4" x 4" electrical boxes.

See our [Plate Size & Back Box Reference Guide](#) for more information.

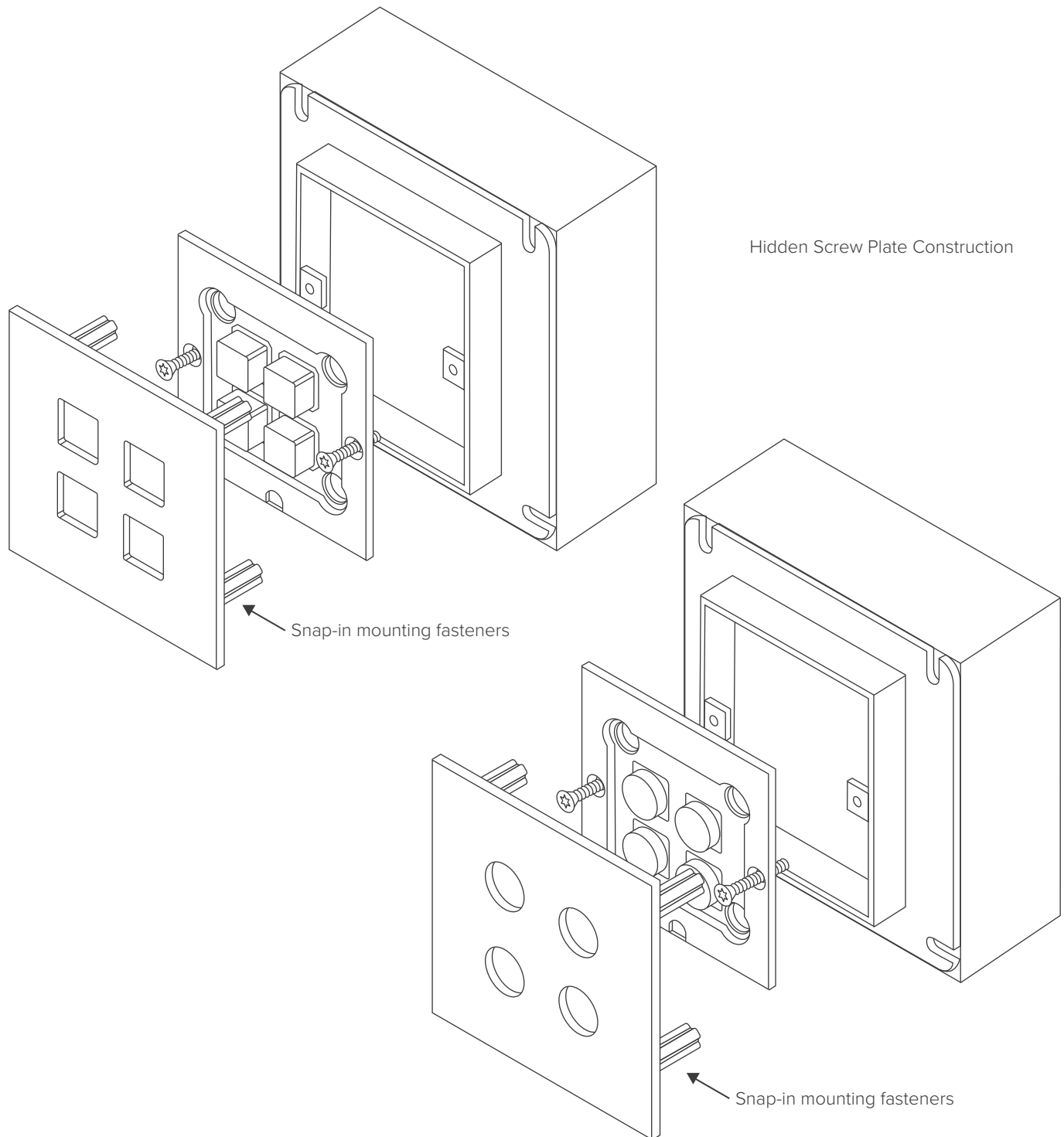

DAMIER KEYPADS – 82 MM || SPECIFICATION SHEET

PROJECT NAME: _____

SPECIFIER: _____

PLATE FINISH: _____

SCREW TYPE Select one

- Visible - Torx Head
- Visible - Slot Head
- Hidden

EDGE TYPE Select one

- Beveled
- Straight

BACK BOX Select one

- MELUS8282R (metal ring for standard 4S junction box)
- MEL8080 (plastic cut-in box)

BUTTONS

SHAPE Select one

- Square
- Round
- Triangle

PROFILE Select one

- Raised
- Flush

CONFIGURATIONS Select one

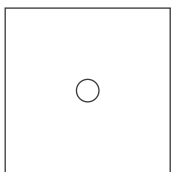

1 BP

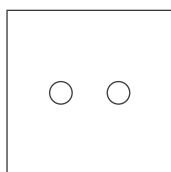

2 BP (R)

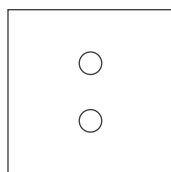

2 BP (C)

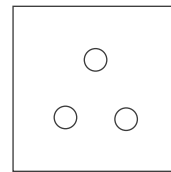

3 BP

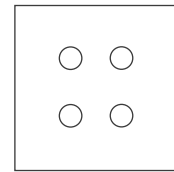

4 BP

Note: if an alternate configuration is required, please contact Meljac North America for confirmation.

ENGRAVINGS

PLACEMENT Select one

- Above Button
- Below Button
- On Top of Button
- No Engravings

STYLE Select one

- Mechanical
- Resin-filled: RAL Color _____
- Screen-Printed
- Back-lit

FONT Select one

- Arial
- Helvetica
- Custom _____

SIZE Select one

- 3 mm
- 3.5 mm
- 4 mm
- Custom _____